



Klever Desk® Electric Double Sided Desk

Click Leg - Quick Start Guide

Caution



Keep children and pets away from the electric high-adjustable desk during the operation. Unplug the power cord during a thunderstorm or if you do not intend to use the desk for long time.



Make sure desktop does not touch the wall.



Ensure no obstacles in the desk's path, and no objects above 20" under the desk.



Working environment temperature 0-40°C, keep products away from corrosive gas, liquid and dusty objects.



It is strictly forbidden to disassemble the products privately to avoid that the failure of the products or the damage to the human body caused by electronic products, etc.



Although the product with anti-collision function, in order to avoid any pinching, please ensures that hands or other parts of your body are in a safe position during the operation. Anti-collision is not enabled during all resets.



Please read following instruction carefully before use the high-adjustable desk. The company does not bear any warranty or liability for damage and human injury caused by any abnormal operation.



It is necessary to be reset manually after initial installation or power off.

Parts

20
min
Assembling time

Two people

Tools

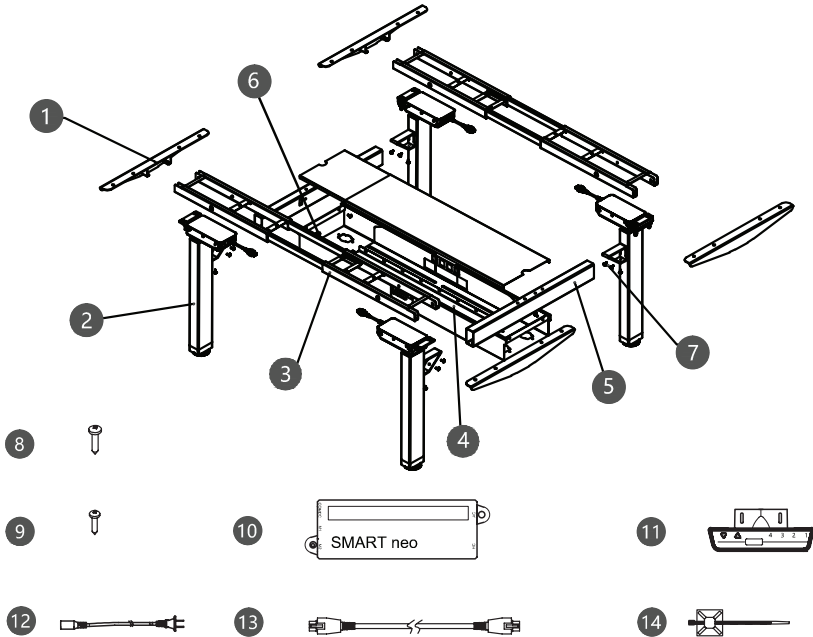

	Part Name	Qty (PCS)
1	Side Bracket	4
2	Column	4
3	Adjustable Frame	2
4	Cable Tray	1
5	Side Rail	2
6	M6*10 Screw	36
7	M8*18 Counter Sunk Head Screw	8

	Part Name	Qty (PCS)
8	ST4.8*16 Tapping Screw	22
9	ST3.5*16 Tapping Screw	8
10	Control Box	2
11	Handset	2
12	Power Cord	2
13	Extension Cable	4
14	Cable Clip	8

Installation

- Step 1:**
- The double sided desk consists of two identical single sided desk systems.
 - Take out one side frame and set the frame flat.
 - Unfold the left and right column respectively and “click” in place and fasten the frames pre-installed screws.
 - The installation method on the other side frame is the same.

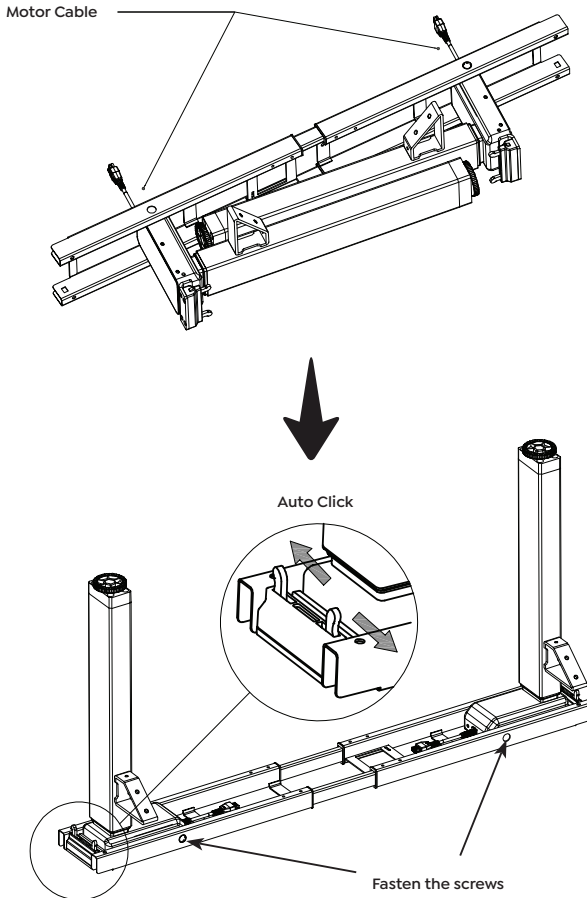

i Unfold when laying down. Avoid damaging the motor cables.

Installation

- Step 2:**
- Place the side brackets onto the frame.
 - Install the bracket screws and fasten the frames pre-installed screws.
 - The installation method on the other side frame is the same.

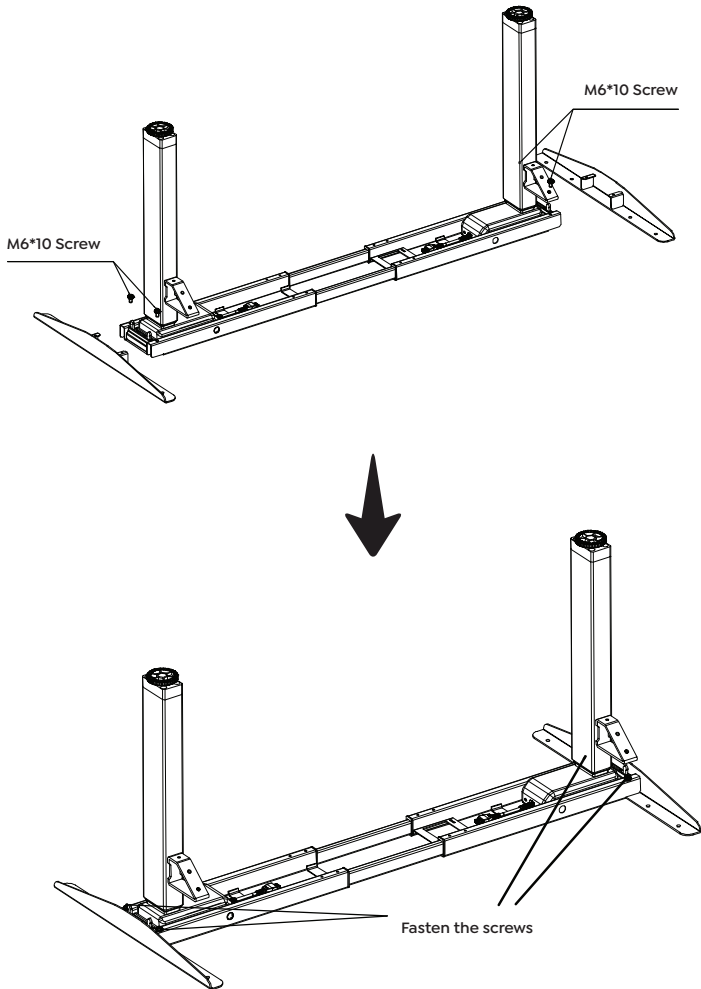

 Avoid excessive tightening of screws

Installation

- Step 3:**
- According to the size of the desktop, adjust the frame to a suitable width (it is suggested that the below measurements are followed when setting the column spacing) and fasten the frame screws.
 - The installation method on the other side frame is the same.

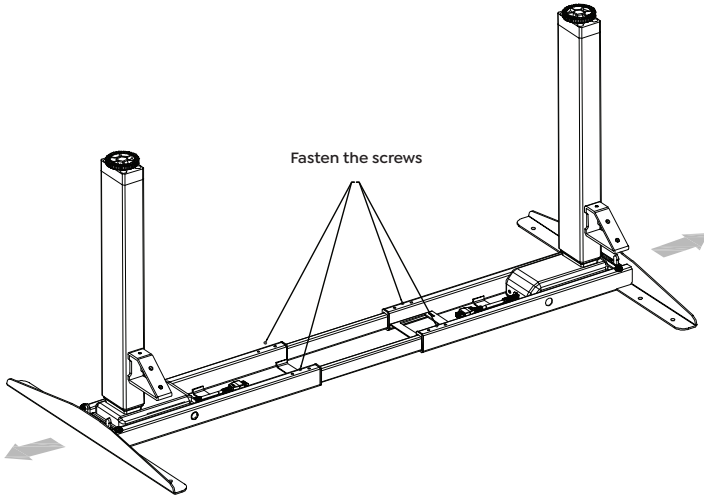

i Avoid excessive tightening of screws. Both sides of the desk must be adjusted to the same width. The frame width is adjustable: 1100 - 1800mm, which is suitable for different desktops.

NOTE: It is recommended the below measurements are used when setting the column spacing for your desk.

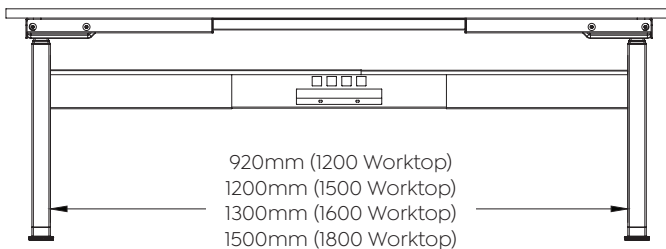

Installation

Step 4: Connect the side rail on one side to the columns and fasten the screws, and then install the other side rail on the other side in the same way.

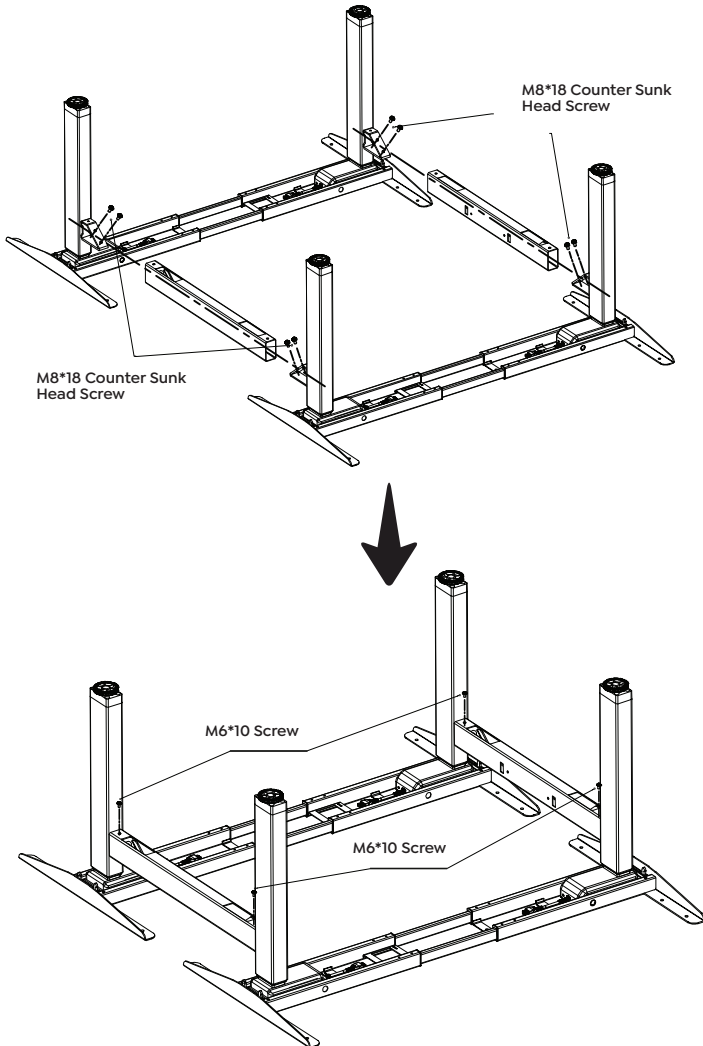

 Avoid excessive tightening of screws

Installation

- Step 5:**
- Turn the frame upright.
 - Take out the cable tray and remove the cover.
 - Insert the cable tray into the side rails and fasten the screws.

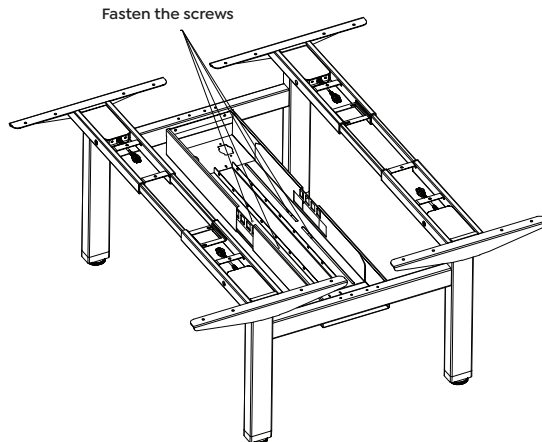
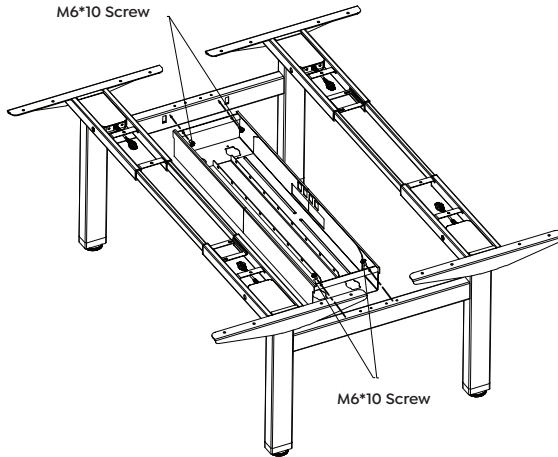

 Avoid excessive tightening of screws

Installation

- Step 6:**
- Installing screen - fix chosen screens brackets (purchased separately) to the side rails and fasten the screws.
 - Place cable tray cover on top of cable tray.

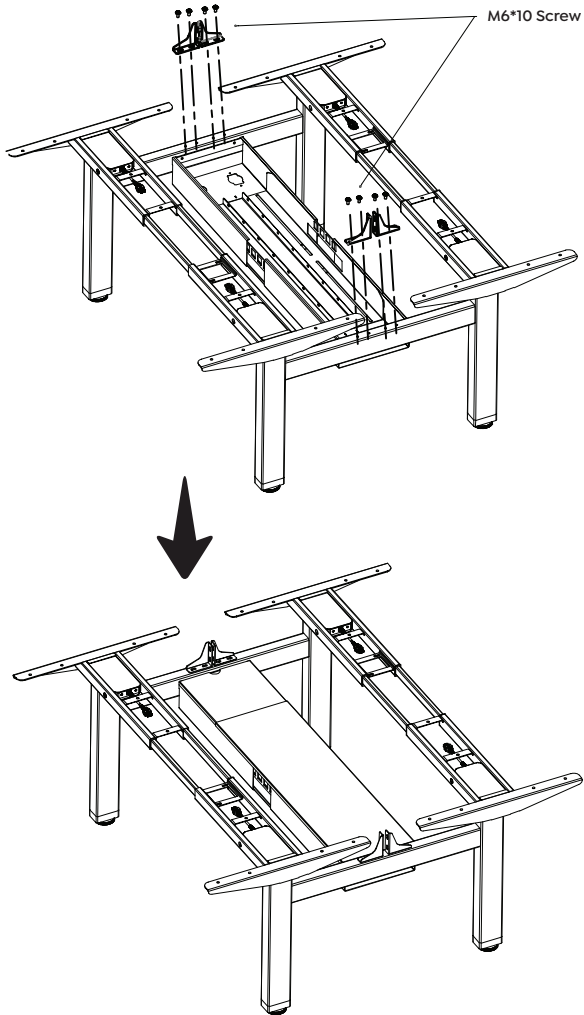

Avoid excessive tightening of screws. Related screws and screen brackets together.

Installation

Step 7: Install screen (purchased separately) with screen brackets and fasten the screws.

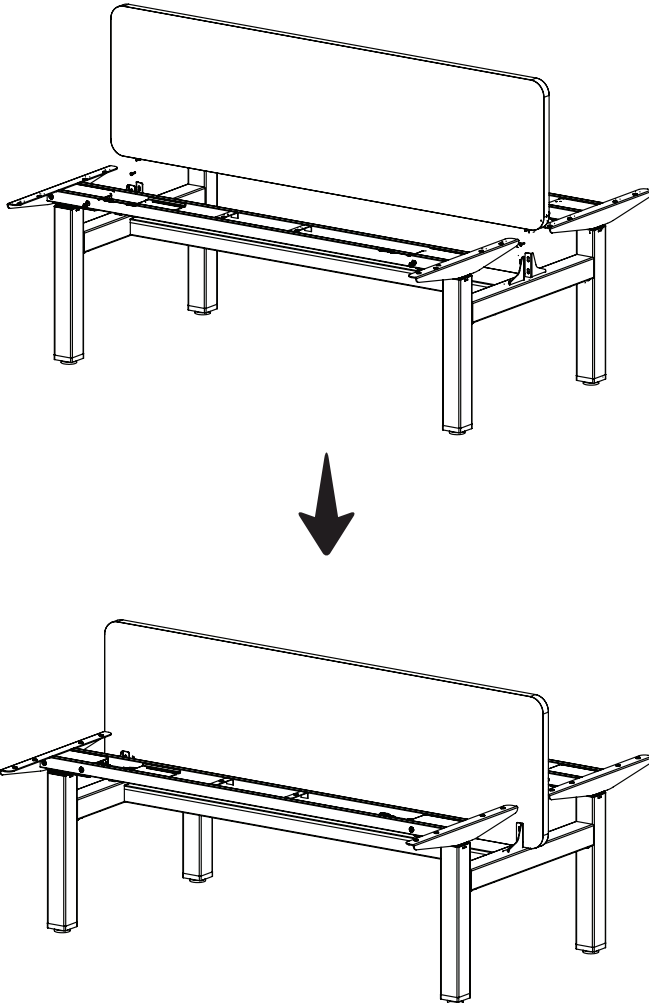

 Avoid excessive tightening of screws. Related screws and screen brackets together.

Step 8: Check both sides of desktop before placing the bottom side of the desktop on the frame (it is suggested that the screen should be 20mm from the edge of the desktop) and fasten screws. Install handset in a suitable position underneath desktop edge to avoid interference with humans or chairs, display screen facing out and fasten screws.

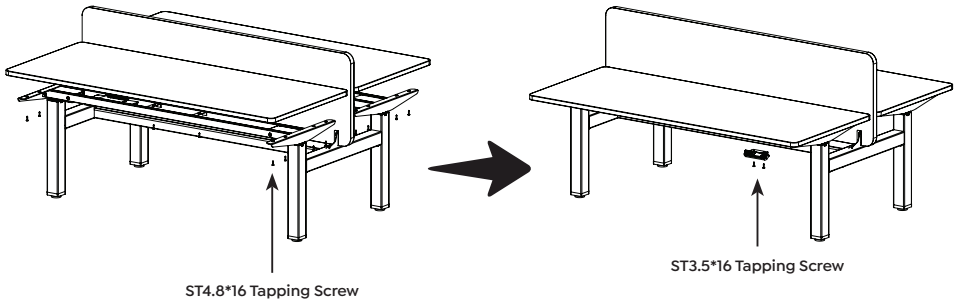

Step 9: Install control boxes on underneath of desktop (see below diagram). Control boxes must be installed flush and away from desk frame.

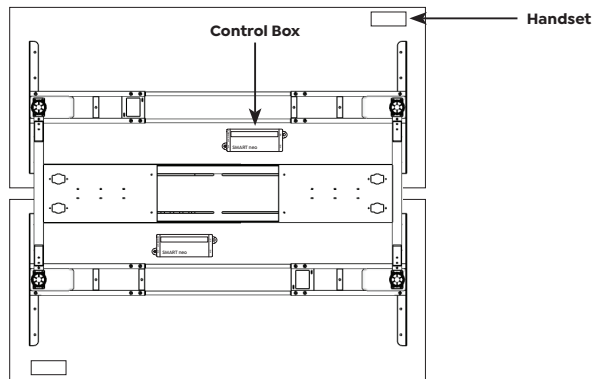

Installation

Step 10: As shown in the below, connect related parts, including control box, handset, extension cable and power cord etc. and fasten with cable clips.

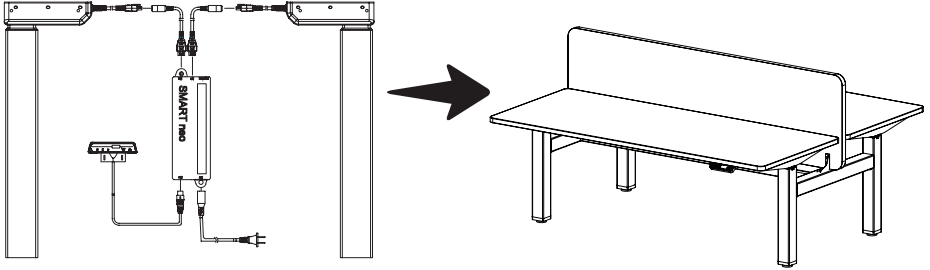

Positioning the Cable Clips

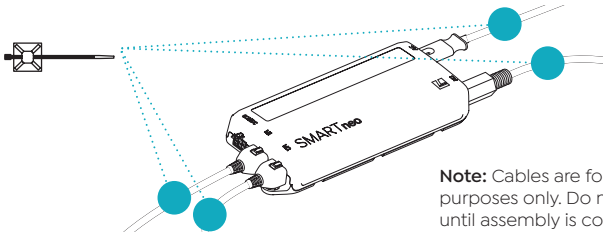

Note: Cables are for illustrative purposes only. Do not attach cables until assembly is complete.

Initial Setup Procedure & Manual Reset

CAUTION

Risk of minor or moderate injury through crushing.

Collision Detection (ISP) is inactive during start-up and reset processes. This may lead to minor or moderate injury through crushing. Ensure that no persons or objects are in the table's range of motion.

NOTICE



Operating the table system when it is not properly connected can damage the product.

- Ensure all Cables are properly connected
- Ensure that all required Actuators are ready to be operated
- Do not operate the Table System until it is properly connected

The Position Reset Procedure is used to align the position of the Actuators within the Table System. You must perform a Position Reset Procedure before using the SMARTneo-2G for the first time.

It is possible to perform a Position Reset Procedure with all types of compatible User Interface. However, this section describes performing a Position Reset Procedure for Table Systems controlled by a Hand Control with an UP Key and DOWN Key (Comfort or Basic Hand Controls).

If your SMARTneo-2G is operated by a different User Interface, consult that product's operating Manual for instructions on performing a Position Reset Procedure.

	1.	Press and hold the DOWN Key until the table stops at the lower position limit
	2.	Release the DOWN Key
	3.	Press and hold the DOWN Key again > The table will move down slightly, then up again
	4.	Release the DOWN Key > The Position Reset Procedure is complete.

INFO

If your SMARTneo-2G has been parameterized with additional stopping points (e.g. a Container Stop Position), repeat Step 3 until the table has moved upwards again.

Adjusting the Table Top Height

CAUTION

Risk of minor or moderate injury through crushing

Your fingers may be crushed when you attempt to change the height of the table.

- Keep fingers away from moving parts
- Ensure that no persons or objects are in the table's range of motion

INFO

The Table Top will move up or down until the UP or DOWN Key is released, or if a predefined stopping point has been reached.

To move the Table Top UP:





	Press and hold the UP Key until the desired height has been reached
---	--

To move the Table Top DOWN:



	Press and hold the DOWN Key until the desired height has been reached
---	--

Saving a Memory Position





This function saves a set Table Top position. One Memory Position can be saved per Memory Position Key.

	1.	Move the table to the desired height
		> The display shows the Table Top height (e.g. 73 cm)
	2.	Press the SAVE Key.
	3.	Press the Memory Position Key (e.g. 2)
		The display shows S 2 > After about two seconds, the Table Top height is displayed again

Adjusting the Table to a Memory Position

	1. Press and hold the required Memory Position Key (e.g. 2). > The Table Top will move until the saved Table Top height has been reached. If you release the Key before the Memory Position is reached, the table will stop.
	2. Release the Memory Position Key > The display shows the Table Top height (e.g. 73 cm)

Factory Reset

	Press and hold the following Keys for 3 seconds: • Memory Position Keys 1 and 2 • UP Key
	The display shows S and a number (e.g. S 4)
	Press the DOWN Key until the display shows S 0.
	The display shows S 0.
	Press the SAVE Key . The SMARTneo-2G has now been reset to its factory settings. It is now in the same state as it was during the first start-up.

Note - E70 will be displayed:

- * Then power off and on control box from mains
- * Display will show 000
- * Then follow initial setup procedure



Container and Shelf Stop Positions

These features can limit the movement area of the Table Top (if e.g. a container is below the table or a shelf is above it). Container Stop Positions become the new lowest end position, Shelf Stop Positions the highest.



INFO

Container Stop Positions can only be saved only in the lower half of the movement area, Shelf Stop Positions in the upper half. You must set each position separately.

To Save a Container Stop or Shelf Stop Position:

	1.	Press the UP or DOWN Key to move the Table Top to the desired position.
	2.	Press and hold the SAVE Key for 10 seconds. > The Container Stop / Shelf Stop Position is saved (Container Stop if you are in the bottom half of the movement area, Shelf Stop if you are in the top half).

To Delete a Container or Shelf Stop Position:

	1.	Press the UP or DOWN Key to move the Table Top to the top half (to delete a Shelf Stop Position) or bottom half (Container Stop Position) of the movement area.
	2.	Press and hold the SAVE Key for 10 seconds. > The Container Stop / Shelf Stop Position is deleted (Container Stop if you are in the bottom half of the movement area, Shelf Stop if you are in the top half).

Error Messages on Display

When a comfort hand control is installed, error messages are displayed on the digital panel.

Signal	Message	Required Actions
HOT The display shows "Hot".	Overheating protection has been activated. Duty cycle possibly exceed.	Wait for the overheated components to cool.
E00 The display shows an error number.	An internal error has occurred.	Read the table below to find the correct response to the error code shown.

Code	Message	Required Actions
E00	Internal Error Channel 1	Disconnect the Control Box from the Mains. Contact KLEVER for further information.
E01	Internal Error Channel 2	Disconnect the Control Box from the Mains. Contact KLEVER for further information.
E12	Defect Channel 1	Disconnect the Control Box from the Mains. Fix the external short circuit. Ensure all cables are connected correctly. Reconnect the system, then operate as normal.
E13	Defect Channel 2	Disconnect the Control Box from the Mains. Fix the external short circuit. Ensure all cables are connected correctly. Reconnect the system, then operate as normal.
E24	Over current Motor M1	Check that nothing is blocking the table's range of movement. Remove excess load from the table. Contact KLEVER for further information.
E25	Over current Motor M2	Check that nothing is blocking the table's range of movement. Remove excess load from the table. Contact KLEVER for further information.
E48	Over current Motor Group	Check that nothing is blocking the table's range of movement. Remove excess load from the table. Contact KLEVER for further information.
E36	Plug detected in M1	Plug in the correct motor. Ensure all cables are connected correctly. Perform a Factory Reset. Perform a Position Reset Procedure.
E37	Plug detected in M2	Plug in the correct motor. Ensure all cables are connected correctly. Perform a Factory Reset. Perform a Position Reset Procedure.
E55	Sync Error, Motor Group	Remove excess load from the table. Perform a Factory Reset. Contact KLEVER.
E62	Stop due to power output control	Check that nothing is blocking the table's range of movement. Remove excess load from the table. Contact KLEVER for further information.

E60	ISP Activated	Release all Keys and wait for the Drive Back function to be completed.
E61	Motor Replaced	Plug in the correct motor. Ensure all cables are connected correctly. Perform a Factory Reset. Perform a Position Reset Procedure.
E65	Over current while driving	Check that nothing is blocking the table's range of movement. Remove excess load from the table. Contact KLEVER for further information.
E67	High Voltage Detected	Disconnect the Control Box from the Mains. Contact KLEVER for further information.
E70	Motor Configuration Changed	Disconnect the Control Box from the Mains. Connect the Actuators in the desired setup. Perform a Factory Reset. Perform a Position Reset Procedure. Read Chapter 9, "Actuator Setup", for advice on changing Actuator types.
E71	Collision Sensor Defective	Perform a Factory Reset. Contact KLEVER if the problem persists.
E72	Position Error (Middle Switch*)	Disconnect the Control Box from the Mains. Wait for at least 20 seconds. Reconnect and perform a Position Reset Procedure.
E73	Middle Switch* Defective	Disconnect the Control Box from the Mains. Contact KLEVER for further information.
E81	Internal Error	Disconnect the Control Box from the Mains. Restart and perform a Factory Reset. Contact KLEVER for further information if the problem persists.
E90	Cascading error (slave)	Check all connections. Attempt a Position Reset Procedure. If this is not possible, disconnect all Control Boxes from the Mains and try again. Contact KLEVER for further information if the problem persists.
E91		
E91		
E93	Connection Error During Cascading	Check all connections. Attempt a Position Reset Procedure. If this is not possible, disconnect all Control Boxes from the Mains and try again. Contact KLEVER for further information if the problem persists.

NOTICE

Do not operate the table system if problems persist. Contact KLEVER for further information.

NOTICE

The Middle Switch is only fitted to certain versions of the SMARTneo-2G. Contact KLEVER if you are unsure which version you have.

Intelligent System Protection

Intelligent System Protection (ISP) is KLEVER's collision detection system. It aims to reduce the risk of system damage when using KLEVER products. When a collision is detected, all Actuators stop immediately and move back in the opposite direction for a few seconds (see 11.2.2 Drive Back Function). The SMARTneo-2G features integrated collision detection via the Light Barrier function. No external sensors are required. The following points must be observed regarding the ISP function.

- ISP sensitivity and ISP shutdown values depend on the complete system (mechanical and electronic components). Contact KLEVER to determine the ISP suitability of your Table System.
- Ensure that a mechanical brake is integrated into the system. This should be effective during downward movement of the table system.
- If no mechanical brake is installed, ISP shutdown sensitivity will be reduced when the table is loaded. However, if there is no load on the table top, ISP will function properly without a brake.
- After ISP is activated, the next movement of the system can only be in the opposite direction.
- ISP shutdown values can be adjusted in the parameters of the SMARTneo-2G. Contact KLEVER for further details.

Maintenance

The SMARTneo-2G is maintenance free for its entire service lifetime. If cleaning is required, wipe the housing with a soft, dry cloth.



WARNING

Moderate risk of serious injury through electric shocks.

While cleaning or maintaining the SMARTneo-2G, liquid intrusion may lead to serious injury through electric shocks.

- Do not allow any components to become wet during cleaning
- Only use a soft, dry cloth to clean the SMARTneo-2G
- Ensure components are placed away from areas where spillages are likely to occur
- Take care not to spill liquids onto or around the SMARTneo-2G



kleverdesk.co.nz